

SINGER
79-103,-104,-105

USE ONLY SINGER OILS and LUBRICANTS

They insure freedom from lubricating trouble and give longer life to sewing equipment

SINGER OIL FOR HIGH SPEED SEWING MACHINES (Cloth and Leather)

For all manufacturing sewing machines except where a stainless oil is desired.

SINGER STAINLESS OIL FOR HIGH SPEED SEWING MACHINES

For all manufacturing sewing machines where a stainless oil is desired.

SINGER MOTOR OIL

For oil-lubricated motors, power tables, transmitters and machinery in general.

SINGER STAINLESS THREAD LUBRICANT

For lubricating the needle thread of sewing machines for stitching fabrics or leather where a stainless thread lubricant is required.

NOTE: All of the above oils are available in 1 quart, 2 quart, 1 gallon and 5 gallon cans or in 55 gallon drums, and can also be supplied in customer's containers.

SINGER GEAR LUBRICANT

This specially prepared grease is recommended for gear lubrication on manufacturing sewing machines.

SINGER BALL BEARING LUBRICANT

This pure grease is specially designed for the lubrication of ball bearings and ball thrust bearings of motors and electric transmitters, ball bearing hangers of power tables, etc.

NOTE: The above greases are furnished in ¼ lb. tubes and 1 lb. and 4 lb. tins.

Copyright, U. S. A., 1914, 1915, 1916, 1924, 1929, 1931, 1934, 1938, 1939 and 1946,
by The Singer Manufacturing Company
All Rights Reserved for all Countries

Form 2951w

INSTRUCTIONS

FOR USING AND ADJUSTING

SINGER SEWING MACHINES

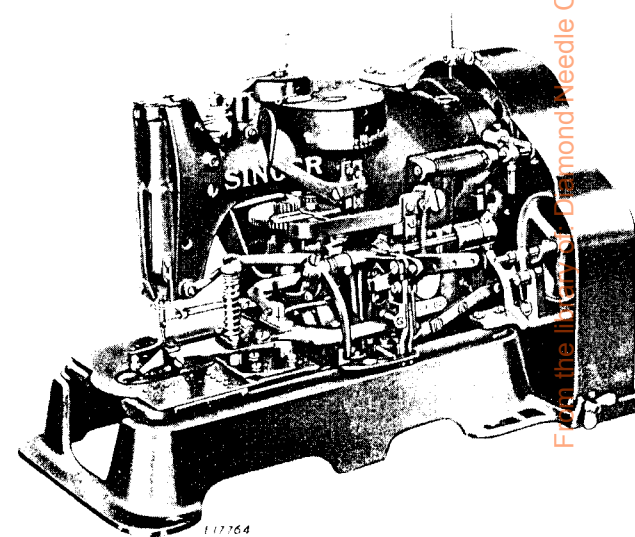

79-103, 79-104 AND 79-105

HIGH SPEED

GEAR DRIVEN FEED

THE SINGER MANUFACTURING COMPANY

TO ALL WHOM IT MAY CONCERN:

The placing or renewal of the name "Singer" (Reg. U. S. Pat. Off.) or any of the Trade Marks of The Singer Manufacturing Company on any machine that has been repaired, rebuilt, reconditioned, or altered in any way whatsoever outside a Singer factory or an authorized Singer agency is forbidden.

THE IMPORTANCE OF USING GENUINE SINGER PARTS AND NEEDLES IN SINGER MACHINES

The successful operation of Singer machines can only be assured if genuine Singer parts and needles are used. Supplies are available at all Singer Shops for the Manufacturing Trade and mail orders will receive prompt attention.

Genuine Singer Needles should be used
in Singer Machines.
These Needles and their Containers
are marked with the
Company's Trade Mark "SIMANCO." 1

Needles in Containers marked
"FOR SINGER MACHINES"
are NOT Singer made needles. 2

DESCRIPTION

Machines 79-103, 79-104 and 79-105 are designed for tacking at high speed.

These machines have a positive, gear driven, intermittent feed which controls the movement of the work clamp so that the stitches are uniformly spaced. The tack is stitched over twice, the first (coarse) stitch being covered during the return travel by a fine stitch.

By simply changing the stitch regulating gear, the number of stitches in the tack can be varied, as desired. (See list of stitch regulating gears on page 15).

The stop motion mechanism of these machines includes a pair of gears having a ratio of 2 to 1 for reducing the speed of the stop cam to one-half the speed of the sewing shaft. The stop cam has two stop notches located diametrically opposite each other so that when the stop motion mechanism is engaged, the stop cam turns only a part of a revolution before the interlocking rod drops into one of the notches to stop the machine. A single, extra-long spiral spring in the stop cam gear helps the machines to stop without shock.

Machine 79-103, for tacking hose supporters to corsets and for similar purposes, makes a whip stitch. The length of tack is adjustable from $\frac{3}{8}$ inch to $1\frac{1}{8}$ inches and the width of bight is adjustable from $\frac{1}{16}$ to $\frac{1}{4}$ inch. A thread trimmer automatically cuts both threads.

Machine 79-104 is designed for tacking straps to underwear, labels to garments, and for similar purposes. It makes a whip stitch. The length of tack is adjustable from $\frac{3}{8}$ inch to $\frac{7}{8}$ inch, and the width of bight is adjustable from $\frac{1}{16}$ to $\frac{3}{16}$ inch. A thread trimmer automatically cuts both threads.

Machine 79-105, for stitching buckles on garters and similar articles, makes a whip stitch. The length of tack is adjustable from $\frac{3}{8}$ inch to $1\frac{1}{8}$ inches and the width of bight is adjustable from $\frac{1}{16}$ to $\frac{3}{16}$ inch. A thread trimmer automatically cuts the under thread.

SPEED

The maximum speed recommended for these machines is 2000 stitches per minute. When the machines are in operation, the driving pulley should turn over to the left as indicated by the arrow in Fig. 4 and Fig. 17.

TO SET UP MACHINES ON SINGER UNIVERSAL POWER TABLES

The machine is usually set so that its face plate is toward the edge of the table nearest the operator, about midway between the leg sections.

Front Edge of Table

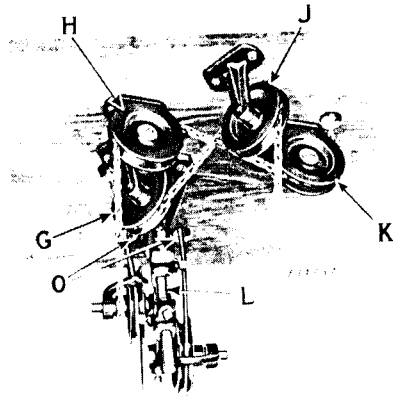

Fig. 2. Underside of Power Table,
Showing Belt and Chain Guides for Low Shaft Drive

One hole should be bored for the chain to connect with the lever R, Fig. 4 and another hole for the chain to connect with the starting lever D2, Fig. 5.

There are four treadle chain pulleys G, H, J and K, Fig. 2, each consisting of a bracket and a single pulley. Fasten one of these pulleys K, Fig. 2 to the underside of the table directly below the clamp lifting lever R, Fig. 4 and in line with the chain adjusting slide on the left hand treadle. Fasten the second pulley H to the underside of the table directly over the chain adjusting slide and in line with the first pulley K. Fasten the pulley G, Fig. 2 to the underside of the table directly below the starting lever D2, Fig. 5 and in line with the chain adjusting slide on the right hand treadle. Fasten the fourth pulley J, Fig. 2 to the underside of the table directly over the chain adjusting slide on the right hand treadle and in line with the pulley G.

Pass one chain from the left treadle straight up and over the pulley H and under the pulley K, then up through the hole in the table and fasten to the clamp lifting lever R, Fig. 4. Pass the second chain from the right treadle straight up and over the pulley J and under the pulley G, then up through the hole in the table and fasten to the starting lever D2, Fig. 5.

If the machine is to be driven by a pulley mounted on either a floor or table shaft to the rear of the idler bracket complete L, the idlers and idler arm should be assembled with the pulleys mounted in the two holes of the arm furthest from the vertical rod hole, as shown at N, Fig. 3. Should it be necessary to drive the machine from a shaft lying between the rear of the machine and the front of the table, the two pulleys should be assembled with the pulleys mounted in the holes of the arms nearest to the vertical rod hole, as shown at M, Fig. 3.

Two belt holes O, Fig. 2 should be bored in the table directly below the machine driving pulley according to the location shown by the blueprint furnished with the machine and the belt idler L, Fig. 2 mounted on the underside of the table directly below these two holes O. The belt should be applied around the pulley on the shaft, around the idlers, up through the holes O in the table and around the pulley on the machine as instructed on page 17.

TO SET UP MACHINES ON UNIVERSAL POWER TABLE WITH SINGER ELECTRIC MOTOR

The foregoing instructions should be followed with the exception that the belt idlers L, Fig. 3 and arms must be assembled as illustrated in Fig. 3. The belt should be applied around the pulley of motor, around the idlers, up through the holes O, Fig. 3 in the table and around the pulley of the machine as instructed on page 17.

Front Edge of Table

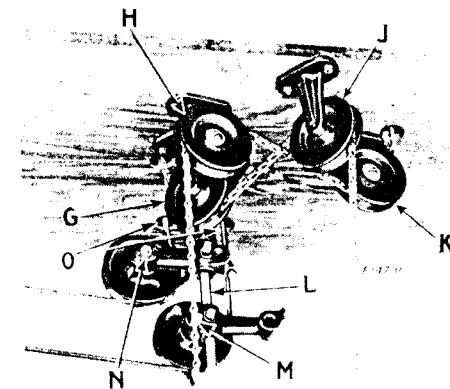

Fig. 3. Underside of Table, Showing Location of
Idler and Treadle Chain Guides for Individual Singer Electric
Motor Operation of Class 79- Machines

From the library of: Grand Needle City

TO OIL THE MACHINE

When the machine is received from the factory, it should be thoroughly cleaned and oiled. Oil should be applied at each of the places designated

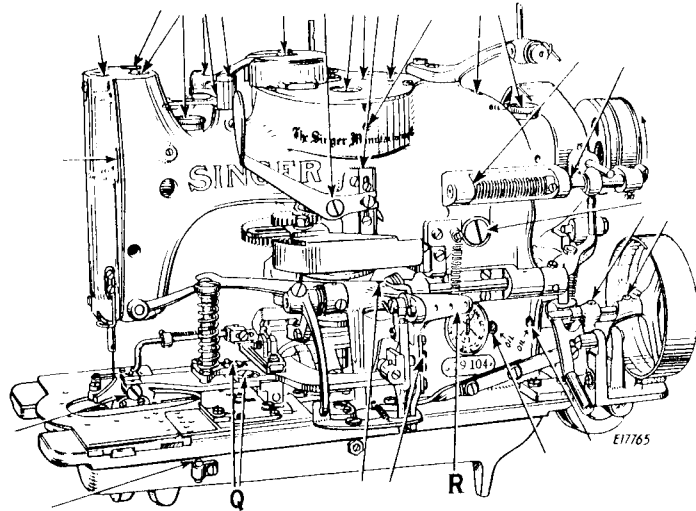

Fig. 4. Oiling Points at the Right of the Machine
Also Adjustments on the Machine

by the unmarked arrows in Figs. 4, 5, 6, 19 and 21. When the machine is in continuous use, it should be oiled regularly to ensure easy running and prevent unnecessary wear of the parts which are in movable contact.

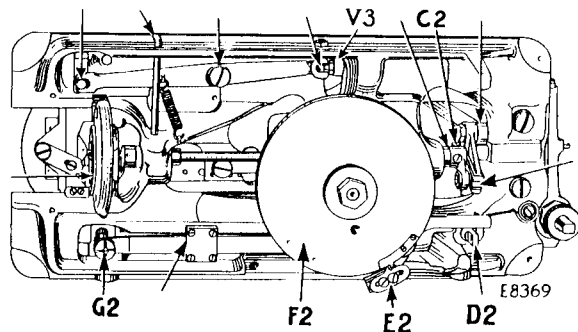

Fig. 5. Oiling Points in the Base of the Machine
Also Adjustments on the Machine

It is advisable to use a heavy grade of machine oil for the feed gears and stop motion mechanism in the rear of the machine.

To reach the parts underneath the bed plate, throw the belt off the pulley of the machine and disconnect the starting and clamp raising chains, then turn the machine over on its hinges.

Occasionally remove the screw **G**, Fig. 6 from the loose pulley and apply a small quantity of Singer Ball Bearing Lubricant to the ball bearing of the pulley through the tapped hole, then replace the screw **G**.

Oil the shuttle bearing at the place indicated by the unmarked arrows in Fig. 19, once each day.

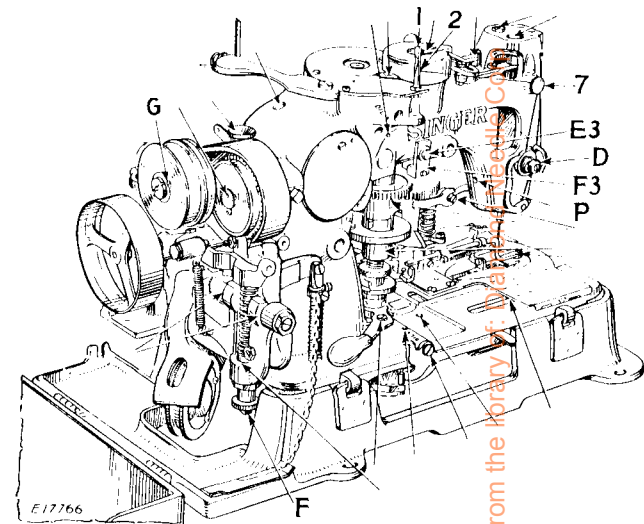

Fig. 6. Oiling Points at the Left of the Machine
Also Adjustments on the Machine

NEEDLES

Needles are of Class and Variety 71x1 and are made in sizes 9, 11, 13, 14, 16, 17, 18, 19, 21 and 22.

The size of the needle to be used should be determined by the size of the thread which must pass freely through the eye of the needle. If rough or uneven thread is used, or if it passes with difficulty through the eye of the needle, the successful use of the machine will be interfered with.

Orders for needles must specify the **Quantity** required, the **Size** number, also the **Class** and **Variety** numbers separated by an x.

The following is an example of an intelligible order:

"100 No. 16, 71x1 Needles"

The best stitching results will be obtained when using the needles furnished by the Singer Sewing Machine Company.

THREAD

Use left twist thread in the needle. Either right or left twist thread may be used on the bobbin.

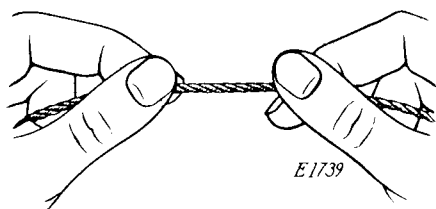

Fig. 7. How to Determine the Twist

Hold the thread as shown above. Turn the thread over toward you between the thumb and forefinger of the right hand; if left twist, the strands will wind tighter; if right twist, the strands will unwind.

Use the same size thread for the needle and the bobbin.

TO REMOVE THE BOBBIN

Reach down under the bed of the machine with the thumb and forefinger of the left hand, open the bobbin case latch **B**, Fig. 12 with the forefinger and lift out the bobbin case.

While the latch remains open, the bobbin is retained in the bobbin case. Release the latch, turn the open end of the bobbin case downward and the bobbin will drop out.

TO WIND THE BOBBIN

Place the bobbin on the bobbin winder spindle and push it up closely against the shoulder, having the small pin in the spindle enter the slot in the bobbin.

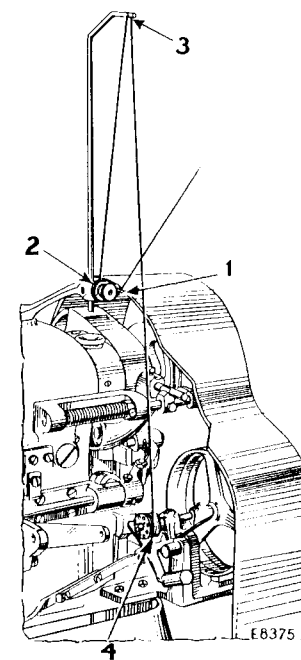

Fig. 8. Winding the Bobbin

Pass the thread from the unwinder, through the thread guide **1**, Fig. 8 on the bobbin winder tension bracket attached to the top of the machine, under between the tension discs **2**, Fig. 8, through the thread guide **3**, Fig. 8, wind the end of the thread around the bobbin **4**, Fig. 8 a few times, then push the bobbin winder pulley against the moving belt. When sufficient thread has been wound upon the bobbin, the bobbin winder will stop automatically. Bobbins can be wound while the machine is stitching.

TO THREAD THE BOBBIN CASE

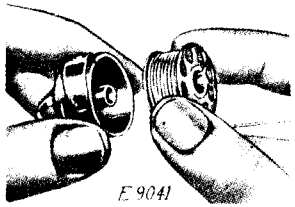

Fig. 9

Hold the bobbin between the thumb and forefinger of the right hand, the thread drawing from the bottom from the left toward the right (see Fig. 9).

With the left hand hold the bobbin case as shown in Fig. 9, the slot in the edge being near the top, and place the bobbin into it.

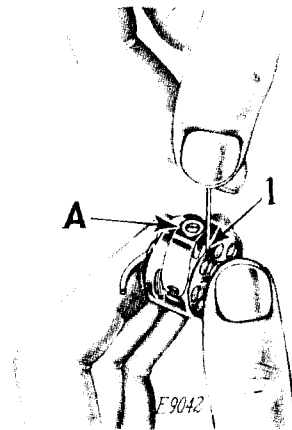

Fig. 10

Then pull the thread into the slot 1, Fig. 10 in the edge of the bobbin case, draw the thread under the thread guide 2, Fig. 11 and under the tension spring 3, Fig. 11, thence through the hole 4, Fig. 11 in the position finger, as shown in Fig. 11.

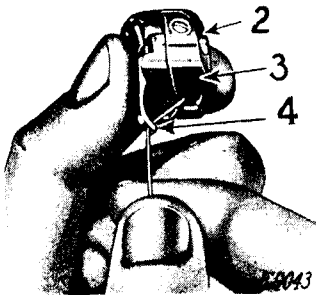

Fig. 11

TO REPLACE THE BOBBIN CASE

After threading, take the bobbin case by the latch B, Fig. 12, holding it between the thumb and forefinger of the left hand. Place the bobbin

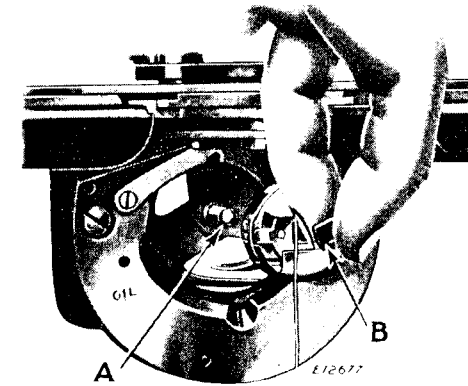

Fig. 12. Replacing the Bobbin Case

case on the center stud A, Fig. 12 of the shuttle body with the position finger opposite the notch at the top of the shuttle race, release the latch and press the bobbin case back until the latch catches the groove near the end of the stud.

TO SET THE NEEDLE

Loosen the set screw in the lower end of the needle bar and put the needle up into the bar as far as it will go with its long groove toward you and the eye directly in line with the arm of the machine, then tighten the set screw.

TO THREAD THE NEEDLE

(See Figs. 6 and 13)

Pass the thread from the thread unwinder, downwardly through the hole 1, Fig. 6 in the top of the thread leader post, through the lower hole 2, Fig. 6 in the post, into the thread retainer 3, Fig. 13, down, under and from back to front between the tension discs 4, Fig. 13, up into the thread take-up spring 5, Fig. 13, under the tension thread guide 6, Fig. 13, up and from back to front through the hole 7, Fig. 13 in the end of the thread take-up lever, into the slot 8, Fig. 13 in the face plate, into the wire thread guide 9, Fig. 13, through the hole 10, Fig. 13 in the lower end of the needle bar and from front to back through the eye of the needle 11, Fig. 13. Draw about two inches of thread through the eye of the needle with which to commence sewing.

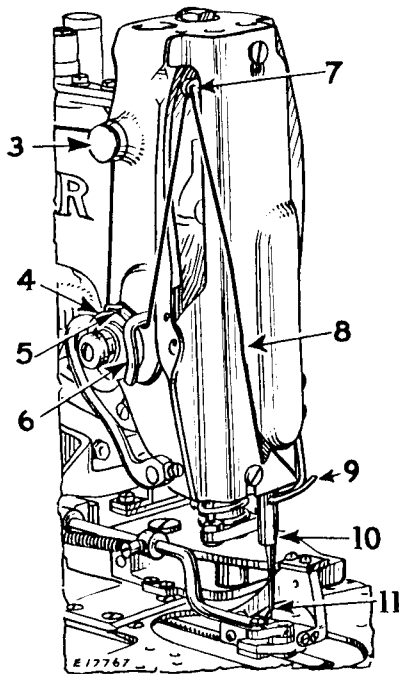

Fig. 13. Upper Threading of Machine

TO PLACE THE FABRIC UNDER THE CLAMP AND START THE MACHINE

Raise the clamp by depressing the left treadle and place the work under the clamp so that the position for the end of the tack nearest you is under the needle, then let the clamp down and start the machine by depressing the treadle at the right.

CAUTION: At all times while operating either treadle, the other treadle should be entirely released.

TO OPERATE THE HAND RATCHETING DEVICE

If the thread should break or the bobbin become empty while stitching, the tack can be quickly repaired at any unfinished part of the stitching by stopping the machine, disengaging the stitch regulating gear and operating the hand ratchet lever, as follows:

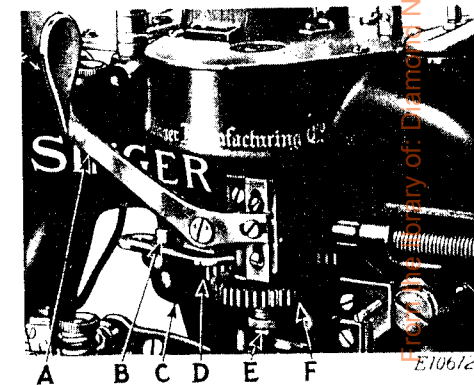

Fig. 14. Mechanism for Disengaging Stitch Regulating Gear

Press down the stop lever J, Fig. 15 and the machine will immediately stop with the needle at its highest point. Then with the right hand push the stitch gear disengaging lever A, Fig. 14 backward to disengage the stitch regulating gear F, Fig. 14 and while holding the lever A backward, operate the hand ratchet lever G, Fig. 15 with the left hand until the work clamps are moved to the desired position.

To re-engage the stitch regulating gear F, release the disengaging lever A, Fig. 14 and operate the machine slowly by means of the hand ratchet lever G, Fig. 15 until the slot in the stitch regulating gear engages the driving pin in the shaft.

CAUTION: Under no circumstances can the machine be hand ratcheted unless the stitch regulating gear F, Fig. 14 is disengaged. When changing

the stitch regulating gear, be sure that the gear slides freely on the shaft and clamping nut sleeve **E**, Fig. 14.

TO REGULATE THE LENGTH OF TACK

Remove the slide from the left side of the bed of the machine. The gauge **H**, Fig. 15, furnished with the machine, is marked according to the

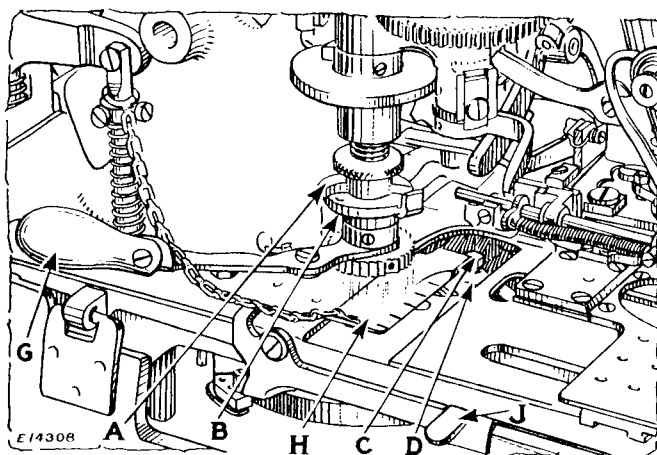

Fig. 15. Showing How to Regulate Length of Tack

length of tack that can be made by the machine. The gauge **H** is also marked with the letters X, A, B, C and D which correspond to similar letters stamped on the collar **B**, Fig. 15 of machines fitted with upper thread trimmers, for positioning the needle thread operating cam.

Loosen the nut **C**, Fig. 15 and place the gauge in the slideway as shown in Fig. 15, having the number on the gauge for the desired length of tack opposite the line in the slideway. Then move the regulating lever **D**, Fig. 15 until the sleeve under the nut **C** rests against the downwardly projecting part of the gauge, and tighten the nut **C**. Now, raise the cam **A**, Fig. 15 and turn it until the pin enters either of the holes X, A, B, C or D, in the collar **B** according to the letter indicated on the gauge opposite the length of tack for which the machine is being adjusted. Then replace the slide in the bed of the machine.

TO CHANGE THE NUMBER OF STITCHES IN THE TACK

The number of stitches in the tack is controlled by the stitch regulating gear **F**, Fig. 14 at the right hand side of the machine. When it is desired to change the number of stitches in the tack, it will only be necessary to change the stitch regulating gear. To remove this gear, loosen the screw **B**, Fig. 14 and swing the bracket **C**, Fig. 14 with the large gear **D**, Fig. 14 out of mesh with the stitch regulating gear **F**. Then remove the nut **E**, Fig. 14 and remove the stitch regulating gear **F** from its shaft.

STITCH REGULATING GEARS

Gear Number	No. of Teeth	Stitches per Tack (Machines 79-104 and 79-105)	Stitches per Tack (Machine 79-103)
249675	18	83	150
249677	20	* 75	135
249679	24	** 62	112
249951	27	55	100
249682	30	* 50	* 90
249725	36	41	* 75
249727	40	* 37	** 67
249744	45	33	* 60
249897	50	30	54
249952	54	28	50
249953	60	25	45

* Regular equipment, unless otherwise ordered.

** Fitted to the machine when shipped from the factory, unless otherwise ordered.

Having selected the gear desired, place it in position on its shaft and securely fasten the nut **E**, Fig. 14 below it.

Swing back the bracket **C**, Fig. 14 as far as it will go so as to bring the large gear **D**, Fig. 14 into mesh with the stitch regulating gear **F**, Fig. 14, then securely tighten the screw **B**, Fig. 14.

TO REGULATE THE TENSIONS

The machine has a thumb nut **D**, Fig. 6 for regulating the tension on the needle thread. This tension should be equal to the tension on the bobbin thread.

The tension on the bobbin thread is regulated by the screw **A**, Fig. 10 in the bobbin case tension spring. To increase the tension, turn this screw over to the right. To decrease the tension, turn the screw over to the left. The tension on the bobbin thread should be light.

TO REGULATE THE WIDTH OF BIGHT

The width of bight is regulated by loosening the nut **V2**, Fig. 16 and moving the stud in the slotted lever at the top of the machine. To increase

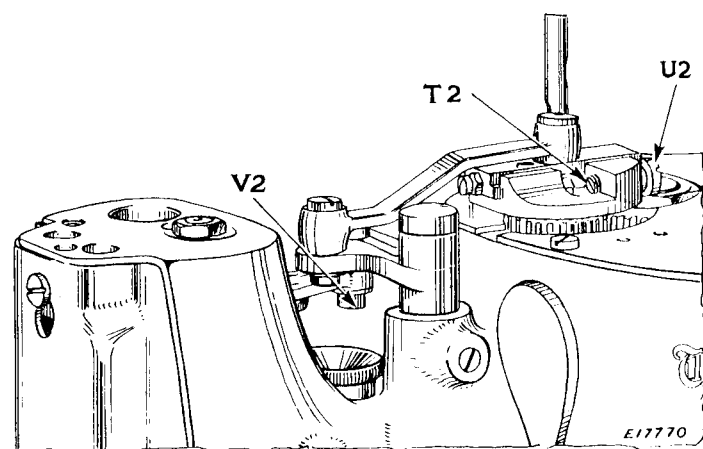

Fig. 16. Adjustments on the Machine

the width of bight up to $\frac{3}{16}$ inch, loosen the nut **V2** and move the stud to the left in the slotted lever. To decrease the width of bight, move the stud to the right in the slotted lever. When the desired width of bight is obtained, securely tighten the nut **V2**.

To further increase the width of bight up to $\frac{1}{4}$ inch, loosen screw **U2**, Fig. 16 and loosen the needle vibrating controlling block screw **E3**, Fig. 6 and raise the block **F3**, Fig. 6. When the desired width of bight is obtained, securely tighten the screw **E3**, turn screw **U2**, Fig. 16 against the slide and secure it in position by tightening set screw **T2**, Fig. 16.

SPECIAL CAUTION

TO APPLY BELT IDLER PULLEY BRACKET AND BELT

The belt idler shown in Fig. 17 prevents damage to the machine in case the belt is applied to drive the arm shaft in the wrong direction of rotation. It instantly forces the belt onto the loose pulley, avoiding improper operation of the machine.

Before starting the machine, firmly attach the idler bracket to the stud at the rear of the machine as shown in Fig. 17, by means of the set screw **A** at the side and the set screw **B** underneath the bracket, pushing the bracket to the right as far as possible so that it rests against the stop.

Since the improved 79-Class machines have a gear driven feed, it is imperative that the arm shaft be turned in the direction of the arrow on the pulley in Figs. 17 and 21. Therefore the belt should lead from the driving side of the shaft or motor pulley to the left hand pulley of the idler **L**, Fig. 2, up through the table to the idler pulley and through the guiding hole as shown in Fig. 17, up and over the top of the loose pulley **C3**, Fig. 21, downward through the belt shifter **B3**, Fig. 21, through the table, around the right hand pulley of idler **L** beneath the table, and back to the motor pulley. The belt idler is so located that should the belt run in the wrong direction, it will force the belt from the driving pulley **W3**, Fig. 21 to the loose pulley **C3**. Whenever the arm shaft is turned over by hand, it should be turned in the direction of the arrow shown in Figs. 17 and 21.

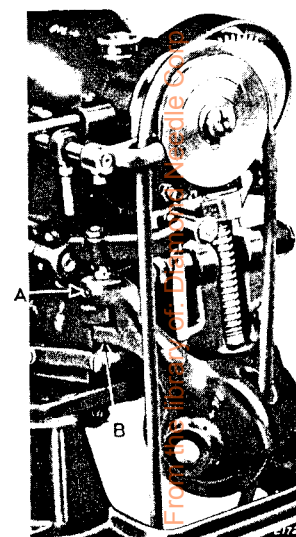

Fig. 17. Rear View of Gear Feed 79-Class Machine

TO SET THE NEEDLE BAR AT THE CORRECT HEIGHT

Turn the driving pulley of the machine until the needle bar moves down to its lowest point. When the needle bar is in this position, the

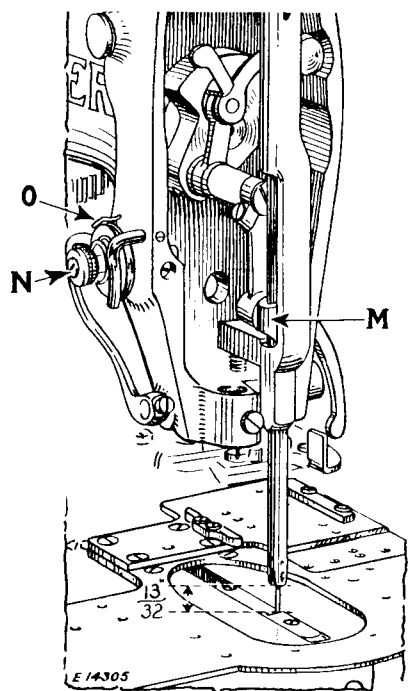

Fig. 18. Showing Correct Height of Needle Bar

bottom end of the needle bar should be about $\frac{13}{32}$ inch above the top surface of the needle plate, as shown in Fig. 18. In case the needle bar is not set at the correct height, loosen the screw which holds the needle bar to the connecting stud **M**, Fig. 18. (This screw can be reached when the needle bar is at its lowest point by inserting the special screwdriver furnished with the machine through the hole **P**, Fig. 6 provided for the purpose in the arm). After loosening the screw, move the needle bar up or down in the connecting stud until it is at the correct height, as instructed above, then securely tighten the screw in the needle bar connecting stud.

TO TIME THE SHUTTLE

Turn the driving pulley of the machine until the needle bar on its left hand throw has moved down to its lowest point and has risen about $\frac{1}{16}$ inch.

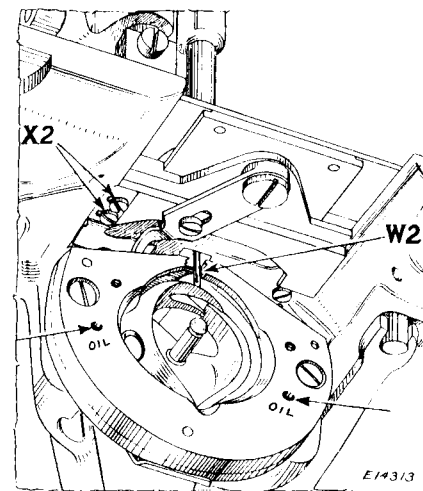

Fig. 19. Showing Shuttle Correctly Timed

When the needle bar is in this position, the point of the shuttle should be at the center of the needle and the eye of the needle should be about $\frac{1}{16}$ inch below the point of the shuttle, as shown at **W2** in Fig. 19. The correct timing of the shuttle is obtained by carefully tightening the upper screw **C2**, Fig. 5 in the shuttle crank squarely against the flat part of the shuttle shaft and then tighten the other screw.

TO ADJUST THE THREAD RETAINER

The thread retainer **3**, Fig. 13 should be adjusted to produce a very light tension on the thread. The tension should only be heavy enough to hold the thread take-up spring forward. To adjust the thread retainer, loosen the set screw at the top and move the thread retainer in or out, as required, then securely tighten the set screw.

TO ADJUST THE THREAD TAKE-UP SPRING

The tension on the thread take-up spring **O**, Fig. 18 should be just sufficient to take up the slack of the needle thread until the eye of the needle reaches the goods in its descent. The tension on the thread take-up spring is regulated by turning the tension stud **N**, Fig. 18 over to the right to increase the tension, or over to the left to decrease the tension.

TO TIME THE FEED WHEEL TRIPPING POINT

The feed wheel tripping point **E2**, Fig. 5 should be set so that it stops the machine immediately after making the final tacking stitch at the finishing end of the tack. To adjust the tripping point **E2** to stop the machine earlier, loosen its two set screws and move it forward. To stop the machine later, move the tripping point **E2** backward, then tighten its two set screws.

TO REMOVE AND REPLACE THE UPPER THREAD CUTTING AND CLAMPING BLADES

Remove the screw **C3**, Fig. 20 from the connecting rod and take out the check holder screw **Z2**, Fig. 20, then remove the clamp check from

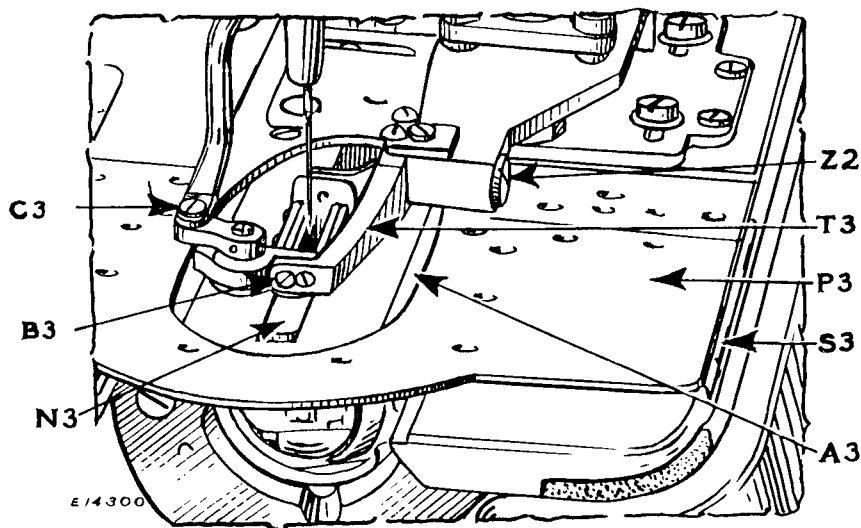

Fig. 20. Adjustments on the Machine

the machine. Remove the screw from the underside of the clamp check which holds the clamping and cutting blades in position and remove the blades.

When replacing the blades, place the clamping blade in position first, next to the clamp check, then put on the cutting blade and securely fasten both blades in position by means of the screw, being careful to set the clamping blade about $\frac{1}{16}$ inch in advance of the cutting blade. Then fasten the clamp check to the machine by means of the two screws **Z2** and **C3**, Fig. 20.

When the clamp check is in position on the machine, the back edge of the cutting blade should be flush with the front edge of the opening in the clamp check. The cutting blade can be set in this position by loosening the two screws **Q**, Fig. 4 and moving the clamp arm forward or backward, as may be required, after which securely tighten the two screws **Q**.

TO REMOVE AND REPLACE THE UNDER THREAD CUTTING BLADE

Turn the machine over on its hinges and remove the two screws **X2**, Fig. 19 which holds the under thread cutting blade in position on the underside of the bed, then remove the cutting blade. Place the new cutting blade in position with its cutting edge between the under thread pull-off finger and the needle plate, as shown in Fig. 19, and replace the two screws. Lower the cutting blade as far as it will go and adjust it straight, then securely fasten it in position by means of the two screws **X2**.

TO REGULATE THE TENSION ON THE STOP MOTION INTERLOCKING ROD

The tension on the stop motion interlocking rod **F**, Fig. 21 should only be sufficient to prevent this rod from jumping out of the notch in the stop cam and sufficiently strong to retard the motion of the arm shaft before finally stopping the machine, thus minimizing the possibility of breaking the stop cam gear spring.

When making tacks in heavy fabrics, it may be necessary to lighten the tension on the interlocking rod. To do this, loosen the lock nut **Q3**, Fig. 21 and turn down the screw **P3**, Fig. 21 until the desired tension is obtained, then securely tighten the lock nut **Q3**.

When making tacks in light weight fabrics, it may be necessary to increase the tension on the interlocking rod **F**, Fig. 21 by turning up the screw **P3**, Fig. 21 until the desired tension is obtained.

NOTE: When the stop cam interlocking rod rides on the highest point of the stop cam, the lock pin **S3**, Fig. 21 should be $\frac{1}{16}$ inch above the stop cam interlocking rod guide **R3**, Fig. 21. If it is not, loosen the lock nut **T3**, Fig. 21 in the tension releaser lever and turn the adjusting screw **U3**, Fig. 21 in or out, as may be required, then securely tighten the lock nut **T3**.

TO REMOVE AND REPLACE THE STOP CAM GEAR SPRING

In case the stop cam gear spring, which is enclosed in the stop cam gear, should become broken, it can be removed and a new spring inserted in its place as follows:

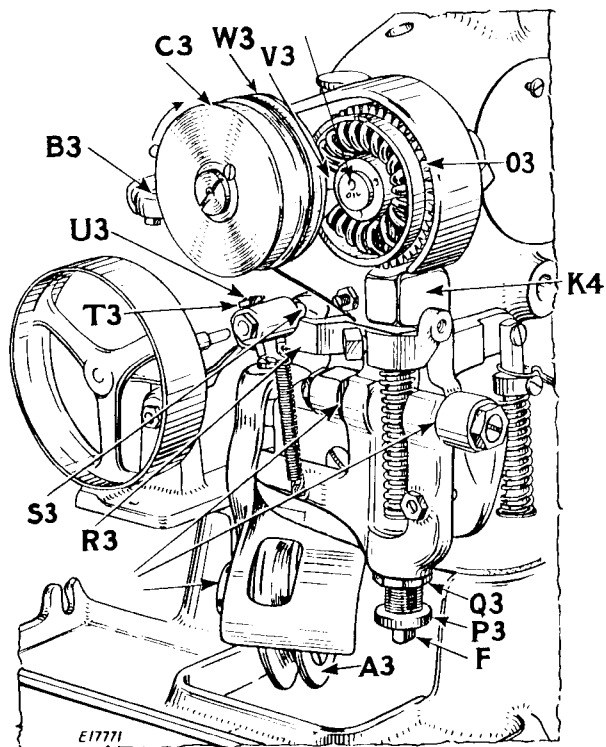

Fig. 21. Showing Spiral Spring in Position in Stop Cam Gear

To remove the spring from the stop cam gear, take out the three screws which fasten the cover to the stop cam gear, then remove the cover. Turn the driving pulley of the machine by hand until the stop cam gear O3, Fig. 21 is in the position shown in Fig. 21, then remove the spring from the stop cam gear.

Place the new spring in position in the stop cam gear, inserting the ends of the spring first.

After the spring is replaced, grease it with Singer Gear Lubricant. This will lengthen the life of the spring. Then replace the cover on the stop cam gear and securely fasten it in position by means of the three screws.

TO ADJUST THE CLAMP LOCK MECHANISM

The clamp lock is designed to prevent the raising of the work clamp while the tack is being stitched.

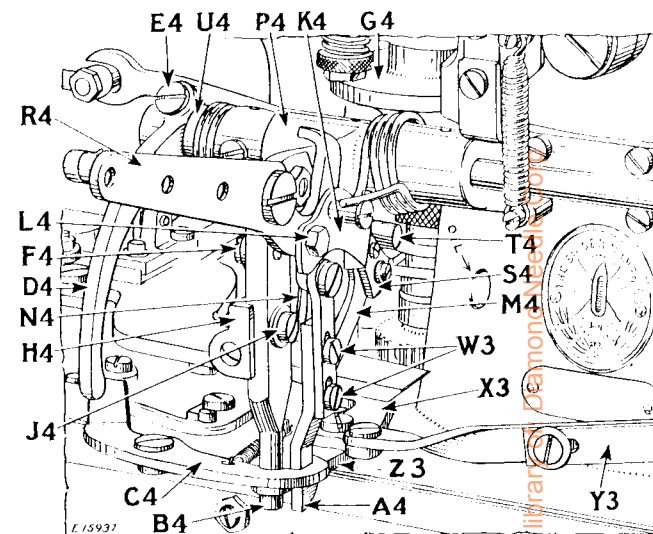

Fig. 22. Locking Mechanism Engaged

When the machine reaches the stopping position, the tripping lever D4, Fig. 22 should throw the clamp lifting arm connection lock C4, Fig. 22 out of the notch in the clamp lifting arm connection B4, Fig. 22, and it should also release the needle thread cutting lever lock A4, Fig. 22.

To adjust the tripping lever D4, Fig. 22, loosen the clamping screw E4, Fig. 22 and set the tripping lever D4 so that it moves the clamp lifting arm connection lock C4 about $\frac{1}{16}$ inch beyond the clamp lifting arm connection B4, as shown in Fig. 23, then securely tighten the clamping screw E4.

To adjust the clamp lifting arm connection B4, Fig. 22, loosen the screw J4, Fig. 22 in the roller stud bracket H4, Fig. 22, then loosen the clamping screw F4, Fig. 22 and raise or lower the clamp lifting arm connection B4 so that the notch in the lower end of the connection B4 will be in line with the lock C4, Fig. 22, then securely tighten the clamping screw F4. Reset the roller stud bracket H4 and securely tighten the screw J4.

TO ADJUST THE NEEDLE THREAD CUTTING LEVER LOCK

The cutting lever lock A4, Fig. 28 is designed to prevent the operation of the needle thread trimmer while the tack is being stitched.

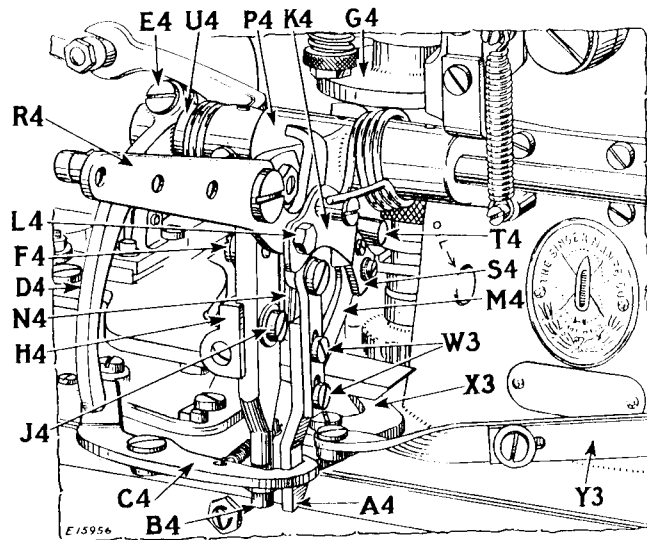

Fig. 23. Locking Mechanism Disengaged

When the machine is in sewing position, the needle thread cutting lever lock A4, Fig. 23 should just lock under the needle thread cutting bracket, as shown at Z3, in Fig. 22.

To adjust the needle thread cutting lever lock A4, Fig. 23, loosen the two clamping screws W3, Fig. 23 and raise or lower the lock A4, as required, then tighten the clamping screws W3.

TO REGULATE THE TRIPPING OF THE UPPER THREAD CUTTING AND CLAMPING BLADES

First, set lever K4, Figs. 22 and 23 by loosening screw L4, Figs. 22 and 23 and adjust the long tail end M4, Fig. 22 so that the sewing safety lock X3, Fig. 22 is in line with back edge of downward projecting arm N4, Fig. 22 of the thread lower cutting lever P4, Fig. 22 and the lever R4, Fig. 22 is lifted to its extreme position by the sewing safety lock X3, Fig. 22, then tighten the screw L4, Fig. 22.

Second, adjust the plate S4, Fig. 22 to or from the stud T4, Fig. 22 to trip the thread (upper) cutting blade connecting rod latch U4, Fig. 22 so that the upper thread cutter of mechanism C3, Fig. 20 is tripped and upper thread is trimmed before the work clamp check Fig. 20 raises from the material.

TO ADJUST THE SEWING SAFETY LOCK

The sewing safety lock X3, Fig. 23 is designed to prevent the operation of the bobbin thread trimmer while the tack is being made.

When the machine is in sewing position, the sewing safety lock X3, Fig. 23 should rest against the thread (lower) cutting lever V3, Fig. 5 above the bed of the machine.

To set the sewing safety lock X3, Fig. 23 in this position, loosen the two screws Y3, Fig. 23 in the safety lock pitman and move the forward end of the pitman, as required, then securely tighten the two screws Y3.

TO ADJUST THE CLAMP CARRIER SLIDE

In case the needle should strike the clamp check T3, Fig. 20 or the needle plate N3, Fig. 20, loosen the two screws beneath the plate P3, Fig. 20 and move the clamp carrier slide S3, Fig. 20 to the right or left, as may be required, until the clamp check T3 and needle plate N3 are clear of the needle, then firmly tighten the two screws.

TO TIME THE BELT SHIFTER

The disc G4, Fig. 22, upon which the belt shifter tripping point is mounted, should be set so that it causes the belt shifter to move the belt from the driving pulley to the loose pulley NOT LESS THAN TWO STITCHES before the interlocking rod drops into one of the notches in the stop cam. To change the timing of the belt shifter, loosen the two set screws in the disc G4 and turn the disc forward to trip the belt shifter earlier or backward to trip it later, then tighten the two set screws.

Care must be taken not to turn the disc G4 so that the belt shifter tripping point is advanced too far. If the tripping point is advanced too far, the machine will not have sufficient momentum to permit the interlocking rod to climb the incline on the stop cam.

CAUTION: When changing the stitch regulating gear and length of tack and timing wheel tripping point, it may be necessary to reset the disc G4, Fig. 22 so that the belt shifter will operate at the correct time, as instructed above.

TO POSITION THE NEEDLE VIBRATING MECHANISM

To correctly position the needle vibrating mechanism, set the arm shaft bevel gear **H**, Fig. 24 and the intermittent feed driving gear **G** so that their timing marks **J** register with each other as shown above, at which

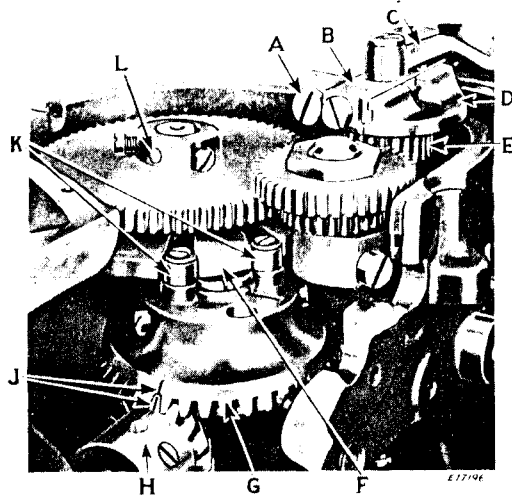

Fig. 24. Needle Vibrating Driving Mechanism

point the driving studs **K** should be on a dead position of the intermittent wheel **F**, which is determined by having the dowel pin **L** face toward the driving pulley, as shown. While the gears **G** and **H** are in this position, the head **D** of the barring shaft should be set so that the adjustable crank slide **B** is approximately in line with the link **C** when the adjusting screw **A** is toward the driving pulley and nearly parallel with the center line of the machine. If the crank slide **B** and link **C** are not set in the correct position in relation to the gears **G** and **H** as described above, re-mesh the gear **E** to bring the mechanism to the required position as stated above.

Improper timing of the gears G and H and incorrect position of the vibrating shaft head **D** will cause deflection of the needle to or away from the shuttle, resulting in breakage of thread or needle and imperfect stitching.